



# Planters Electric Membership Corporation

A Touchstone Energy® Cooperative 

## Requirements for New Service

- 1- Fill out application for new service and pay membership fee and deposit. We require a copy of plat from the tax assessors office (8 ½ X 11 copy). Easement also has to be a notarized original. (*no copies*). Have 911 (physical) addresses when paperwork is turned in.
- 2- Call engineering department 2 days after paperwork is turned in if there are questions about line placement, meter pole placement or construction cost. Engineering department should be contacted between **8:00 a. m. - 9:00 a.m.** Monday through Thursday. (*Mobile homes have to be on site before engineering department comes out.*)
- 3- After your electrician wires service, have inspected by your county's zoning department. ***Planters EMC cannot schedule a new service until approval from zoning department is received.***
- 4- After above steps are completed, service will be connected within 10 – 14 working days.

---

### Zoning Office Contact Info

Bulloch County Zoning Office – 912-489-1356  
Burke County Zoning Office – 706-554-8758  
Effingham County Zoning Office – 912-754-2128  
Emanuel County Zoning Office – 478-237-6514  
Jenkins County Zoning Office – 478-982-2563  
Richmond County Zoning Office – 706-312-5050  
Screven County Zoning Office – 912-564-2951

### 911 Address Assignments

Burke Co Zoning – 706-554-8758  
Screven Co E-911 – 912-564-5868  
City of Millen – 478-982-6100  
Augusta IT GIS Dept – 706-821-2514  
Bulloch Co GIS Dept – 912-764-2181  
Effingham Co GIS Dept – 912-754-2128  
Emanuel Co E-911 – 478-237-3169

---

### Planters EMC Engineering Department Contact Information

478-982-4722, 706-554-1811 or 912-564-7163 (*then dial extension # below*)

Daniel Griffin - Extension 251

Sawyer Newton – Extension 225

Jacob Oglesby - Extension 236

**\* Any construction cost has to be paid before service is built.**



**Planters Electric  
Membership Corporation**  
A Touchstone Energy® Cooperative 

# APPLICATION FOR ELECTRIC SERVICE

## Applicant Information Sheet

\*\*\* A Copy of your Driver's License or valid photo ID must be attached. **(send in fine or photo mode if faxed)**

Please Print Clearly Contact info: Phone#: 478-982-4722 fax#: 478-982-4798 email: [apply@plantersemc.com](mailto:apply@plantersemc.com)

<b>Name:</b>	
Mail in care of Name (if other than above):	
<b>Mailing address:</b>	
(Street)	(City) (State) (Zip)
<b>Physical Service Address:</b> <small>(Your 911 address ** Required **)</small>	
<small>(cannot be a P.O. Box)</small> (Street)	(City) (State) (Zip)
Home Phone #: (        ) -	WORK Phone #: (        ) -
Cell Phone #: (        ) -	Drivers License #:
Cell Phone Provider:	Social Security #:
<b>Meter #:</b>	
Email Address:	<b>EBilling</b> YES <input type="checkbox"/> NO <input type="checkbox"/>
Spouse's Name:	<b>Email Reminders</b> YES    NO
Spouse's Social Security #:	<b>Text Notifications</b> YES    NO
<b>Type of Service</b> Residence: <input type="checkbox"/> Pump: <input type="checkbox"/> Mobile Home: <input type="checkbox"/> Clubhouse: <input type="checkbox"/> Other: <input type="checkbox"/> <b>Rent:</b> <input type="checkbox"/> <b>Own:</b> <input type="checkbox"/>	
<b>Have you ever been served by Planters EMC in the past?</b> YES <input type="checkbox"/> NO <input type="checkbox"/>	
<b>Signature:</b>	Date:

### **Overhead/Underground Electrical Service Construction Agreement**

Owner agrees to assume all responsibility for repairs, replacement, re-grassing, etc. of water lines, driveways, roadways, underground utilities, and septic tanks or other property upon completion of construction/excavation, overhead or underground, for electric service provided by the Cooperative (provided reasonable care is exercised by the Cooperative.) Due to reasons beyond the control of the Cooperative, (i.e. bad weather, power interruption, unscheduled maintenance, inability to place equipment due to wet ground or previous scheduling obligations) Planters EMC cannot make commitments with regard to when line construction may begin on any project.

*According to the Fair Credit Reporting Act, § 604. Permissible purposes of consumer reports [15 U.S.C. § 1681b]. Planters EMC has the right to review your personal credit file under these conditions (F) otherwise has a legitimate business need for the information, (i) in connection with a business transaction that is initiated by the consumer; or (ii) to review an account to determine whether the consumer continues to meet the terms of the account. Planters Electric determines deposits based on a credit inquiry.*

### ===== **BELOW IS FOR OFFICE USE ONLY** =====

Membership Fee: \$ 10.00	Account Set-Up Fee: \$25.00	Meter Deposit: \$	Total: \$
Account #:	Meter #:		
Location #:	S.O. #:		
<b>Comments:</b>			
<b>Signature of PEMC representative:</b>			
Date:    /    /			

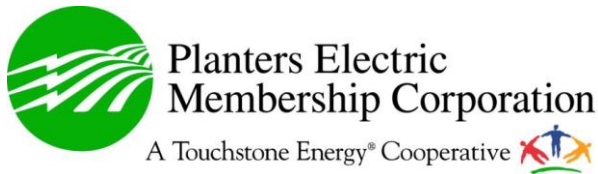

(Office Use Only)

ACCOUNT # \_\_\_\_\_

MAP NUMBER \_\_\_\_\_

## APPLICATION FOR MEMBERSHIP

The undersigned (hereinafter called the "Applicant") hereby applies for membership in, and agrees to purchase energy from the Planters Electric Membership Corporation (hereinafter called the "Association") upon the following terms and conditions:

1. The Applicant will pay the Association the sum of \$10.00, which if this application is accepted by the Association, will constitute the Applicant's membership fee. The Applicant expressly agrees that the Association may, prior to the acceptance of this application use the \$10.00 for the development of a rural electrification project. If the Association is unable to obtain a loan from the Rural Electrification Administration to finance the construction of such a project, the Applicant agrees that only so much of the \$10.00 as has not been expended for the development expenses will be returned to him. If the Association succeeds in establishing rural electrification project but is unable to furnish service to the Applicant, the sum of \$10.00 will be refunded to the Applicant.

2. The Applicant will, when the electric energy becomes available purchase from the Association all electric energy used on the premises described below and will pay therefore monthly at rates which will be fixed by the Board of Directors of the Association. The Applicant will pay a bill of at least \$ \_\_\_\_\_ per month regardless of the number of kilowatt hours consumed.

3. The Applicant will cause his premises to be wired in accordance with wiring specifications approved by the Association, the Applicant's house approximately \_\_\_\_\_ feet from the proposed distribution lines of the Association, or from the road.

4. The Applicant will comply with and be bound by the provisions of the charter and bylaws of the Association, and such rules and regulations as from time to time, may be adopted by the Association.

The acceptance of this application by the Association shall constitute an agreement between the Applicant and the Association, and the contract for electric service shall continue in force for one year from the date service is made available by the Association to the Applicant, and thereafter until canceled by at least 30 days written notice given by either party to the other.

Applicant Name: \_\_\_\_\_

Applicant's Mailing Address: \_\_\_\_\_

Property Address: \_\_\_\_\_

Owner of Property: \_\_\_\_\_

Owner's Mailing Address: \_\_\_\_\_

This will be a new service to a \_\_\_\_\_ on \_\_\_\_\_ acres located on \_\_\_\_\_ Road/Hwy.

Nearest Neighbor: \_\_\_\_\_ RS: \_\_\_\_\_ Loc: \_\_\_\_\_

(PEMC office use only)

Member sep # \_\_\_\_\_

Location # \_\_\_\_\_

**PLANTERS ELECTRIC MEMBERSHIP CORPORATION  
RIGHT-OF-WAY EASEMENT**  
P.O. BOX 979 - MILLEN, GA 30442

**KNOW ALL MEN BY THESE PRESENTS:** That the undersigned, for good and valuable consideration, the receipt of which is hereby acknowledged, does hereby grant unto the **PLANTERS ELECTRIC MEMBERSHIP CORPORATION (hereinafter, "Planters")**, whose mailing address is Post Office Box 979, Millen, Georgia 30442, the right and privilege to go in, upon, along and over, that lot or parcel of land identified as Parcel \_\_\_\_\_ on the records of the Tax Assessor of \_\_\_\_\_ County, Georgia, and which tract is more particularly described on the records of the Clerk of Court of \_\_\_\_\_ County, Georgia, in a deed recorded in Deed Book \_\_\_\_\_ Page(s) \_\_\_\_\_, or a plat recorded as \_\_\_\_\_, and which is made a part of this easement by reference.

The easement is fifty (50) feet in width, being twenty-five (25) feet on either side of the center line of the system **described in more detail in the drawing attached to this easement as Exhibit "A"** and installed for the following purposes: to construct, reconstruct, relocate, renovate, remove, repair, operate and maintain on or under the above described lands, an electrical distribution line and its attendant poles, guy wires, transformers, and other related equipment or appurtenances, or similar distribution line or system; to cut, trim, eradicate and control the growth, by chemical means, machinery or otherwise, of trees, shrubbery, roots, and the like, which may interfere with or threaten to endanger the operation and maintenance of the line or system (including the control of the growth of other vegetation in the right-of-way which may incidentally and necessarily result from the means of control employed); and to license, permit or otherwise agree to the joint use or occupancy of the line or system by any other person, association or corporation, for utility or communication purposes.

The undersigned Grantor agrees that all wire, lines, conduit, cables, poles, guy wires, transformers, and other facilities installed on, above or below the above-described lands at Planters' expense shall remain the property of Planters, removable at its option upon termination of this easement.

The undersigned Grantor covenants and agrees that no barrier of trees, shrubs, or the like, and no structure or building shall be placed on the easement premises without the express written consent of Planters.

This easement includes such additional rights of use and occupancy as shall be necessary for the use, maintenance, and operation of Planters' system on said right-of-way.

The undersigned Grantor covenants that Grantor owns the lands over which this easement is granted and that there are no liens or encumbrances whatsoever which might limit, restrict or otherwise interfere with Grantor's right to grant the easement.

**IN WITNESS WHEREOF**, the undersigned has set hand and seal this \_\_\_\_\_ day of \_\_\_\_\_, 20\_\_\_\_\_.

Signed, sealed and delivered in the presence of:

\_\_\_\_\_  
Grantor (Signature)

\_\_\_\_\_  
Witness

\_\_\_\_\_  
Print Name

\_\_\_\_\_  
Notary Public

\_\_\_\_\_  
Grantor (Signature)

My Commission Expires:

\_\_\_\_\_  
Print Name

# Planters Electric Membership Corporation Customer Entrance Specifications

## Meter Pole

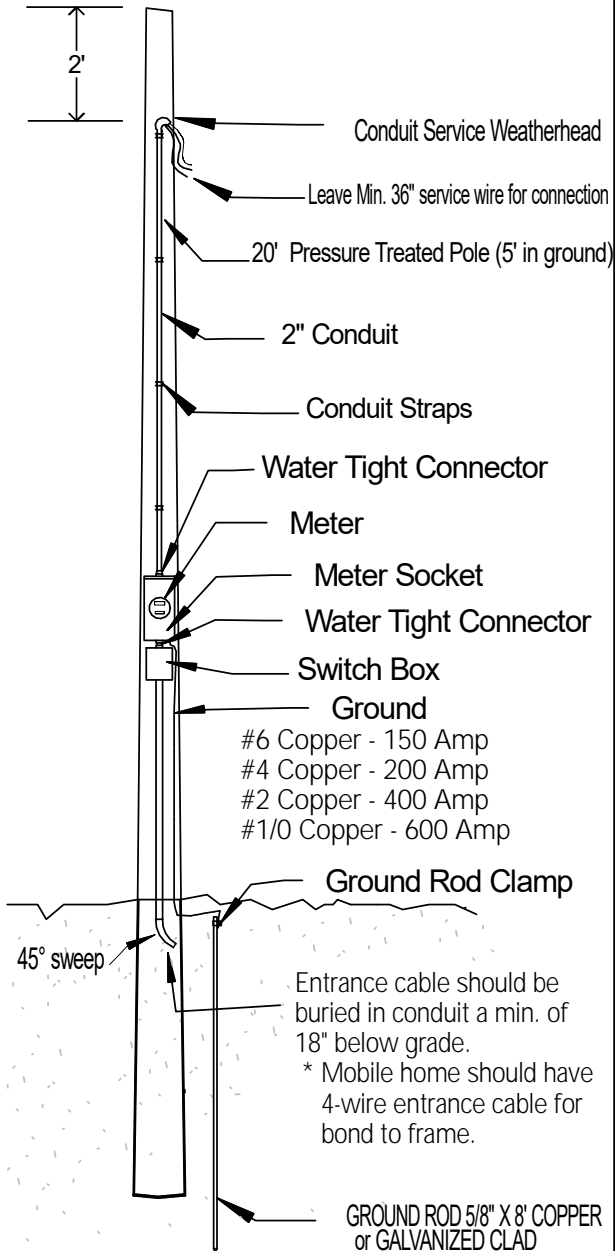

## Overhead Service

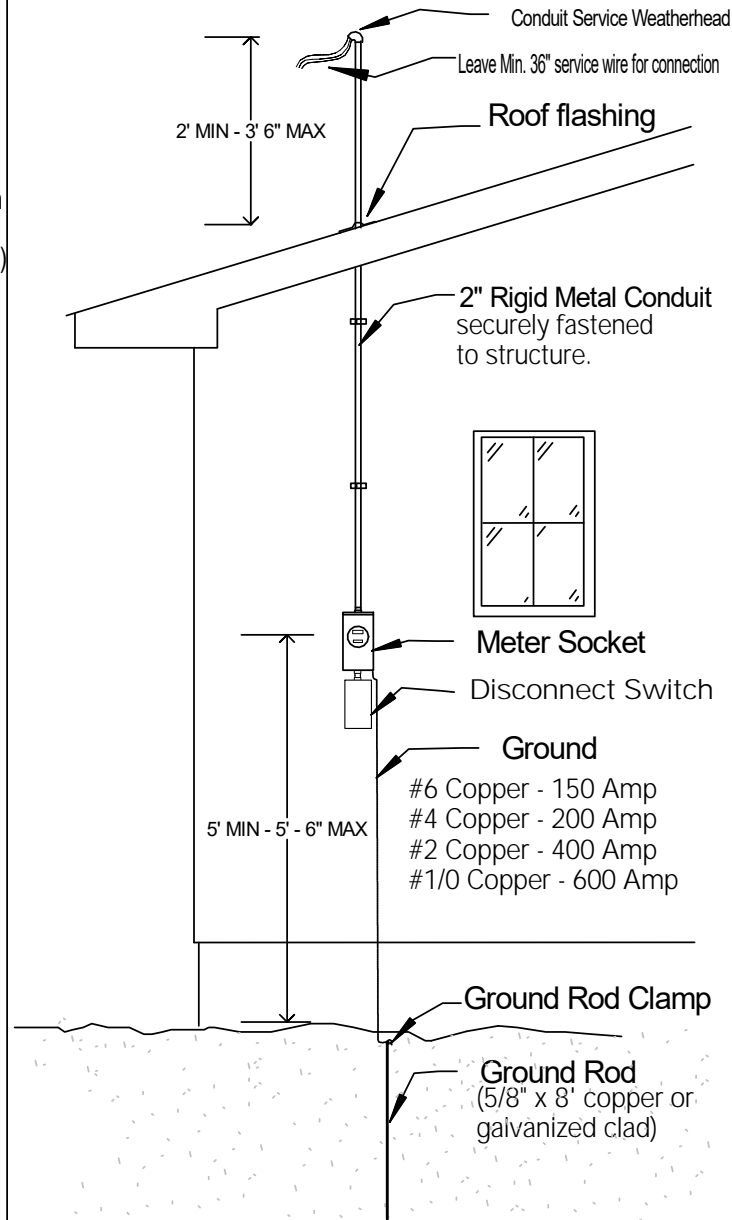

## Underground Service

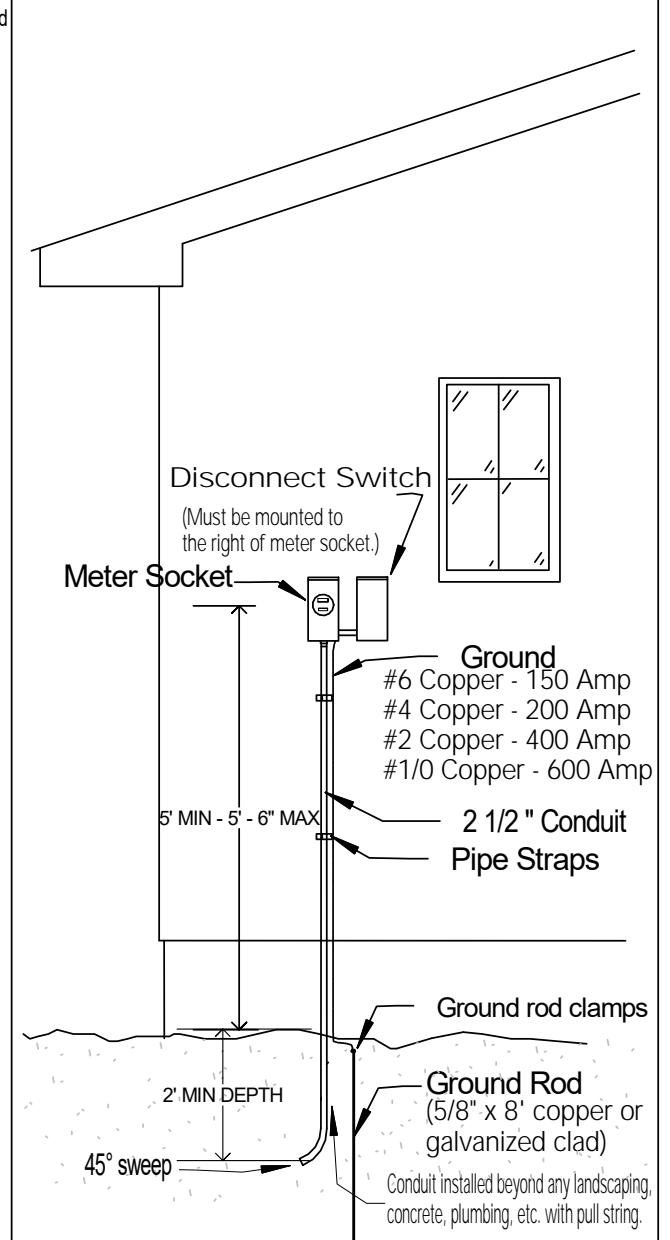

All wiring requirements are subject to change and should conform to individual county zoning requirements. All items pictured are to be provided by the consumer except for the meter. Diagrams above meet minimum requirements of the 2011 National Electric Code.